

DF SERIES
DUST FIGHTERS

GENERAC FACTORY



A LEADING ITALIAN COMPANY SINCE 1997

Since 1997, we have dedicated ourselves to the production of mobile light towers. This focus has allowed us to develop innovative products with high performance, versatility and reliability. In 2013 Tower Light was acquired by Generac Power Systems, Inc., the leading American manufacturer of commercial, industrial and portable power generators. This acquisition allowed Tower Light to take a new step forward the development of new innovative products, as well as to increase the available product range. On March 2015 Tower Light Srl has changed its name into Generac Mobile Products Srl. We are a company with ISO 9001 certification and we have established ourselves as the dominant player in the European market, with a worldwide presence and a continuous growth throughout the years.



R&D



Thanks to our efficient, fast and reliable Research and Development Team, Generac Mobile® since its birth in 1997 has put many milestones on its path. Our Research and Development department has been developing innovative and unique solutions in the market, up from its origins, like the vertical telescopic mast, LED lamps and hybrid engine configurations. R&D skills and twenty years of experience allowed Generac Mobile® to launch on the market new products like: power generators, diesel-driven pumps, dust control units, anti-theft boxes and closed water loop washing bays. R&D staff is 100% focused on increasing the quality of our products and constantly develop new customer oriented solutions.

SPARE PARTS



Customers are always at the center of every daily action made in Generac Mobile®. The management of spare parts are a great strength point of our organization. Our factory warehouses will meet any request with a real time shipments through express courier. Our spare parts inventory covers every single machine ever manufactured; the service is rapid, efficient and complete and over 90% of orders received are carried out within 48 hours, thanks to a dedicated staff operating with a series of brand-new automated spare parts storage systems. Spare parts service is also supported by authorized workshops of the manufacturers of the engines used on our power generators. They are able to take action quickly and replace damaged engine components with original parts.

SERVICE



Ensuring a good and quick after-sales service is our first objective here in Generac Mobile®. As part of our business philosophy we believe that if a product is not followed by an adequate after-sales service, then it does not even make sense for this product to exist. Generac Mobile® is constantly focused on developing a network of local service centers across the world able to fix any problem with the best professional approach. As well as being able to support our customers via e-mail or by phone, our Service department is available for technical courses anywhere in the world. At the end of the training, attendees always receive a training-certificate stating that the customer is appointed as an authorized Generac Mobile® workshop in the country of origin.

DUST SUPPRESSION

TRADITIONAL SYSTEM

Using a traditional dust suppression system through a water hose, you can obtain water particles with a 1000 micron average diameter: these particles are not able to catch dust particles that have a 80 micron diameter instead. Moreover, the water flow passes through the dust cloud without covering it completely.



DUST FIGHTER SYSTEM

Nebulized water particles have a 50-150 micron diameter: they can easily combine themselves with dust particles with same dimensions and drag them to the ground. Moreover, nebulized water can completely cover the dust cloud.

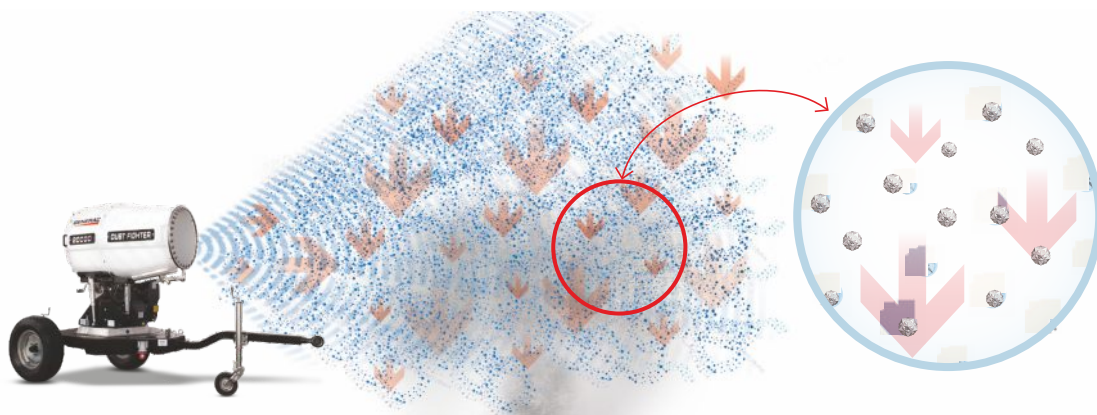

DUST FIGHTER RANGE FEATURES

- Water consumption reduction compared to traditional techniques
- More effective dust suppression thanks to the nebulized water
- Automatic operation
- No formation of muddy surfaces
- Large working area

MAIN APPLICATIONS



DEMOLITIONS

QUARRIES

WASTE DUMPS

Also ideals for: concrete and aggregates production and recycling, environmental repairs, steel and slag treatment landfills, wood and aluminum processing.

PERFORMANCES

The Dust Fighter range is composed by different models which differ from each other for performances and size of the area covered by the nebulized water flush.

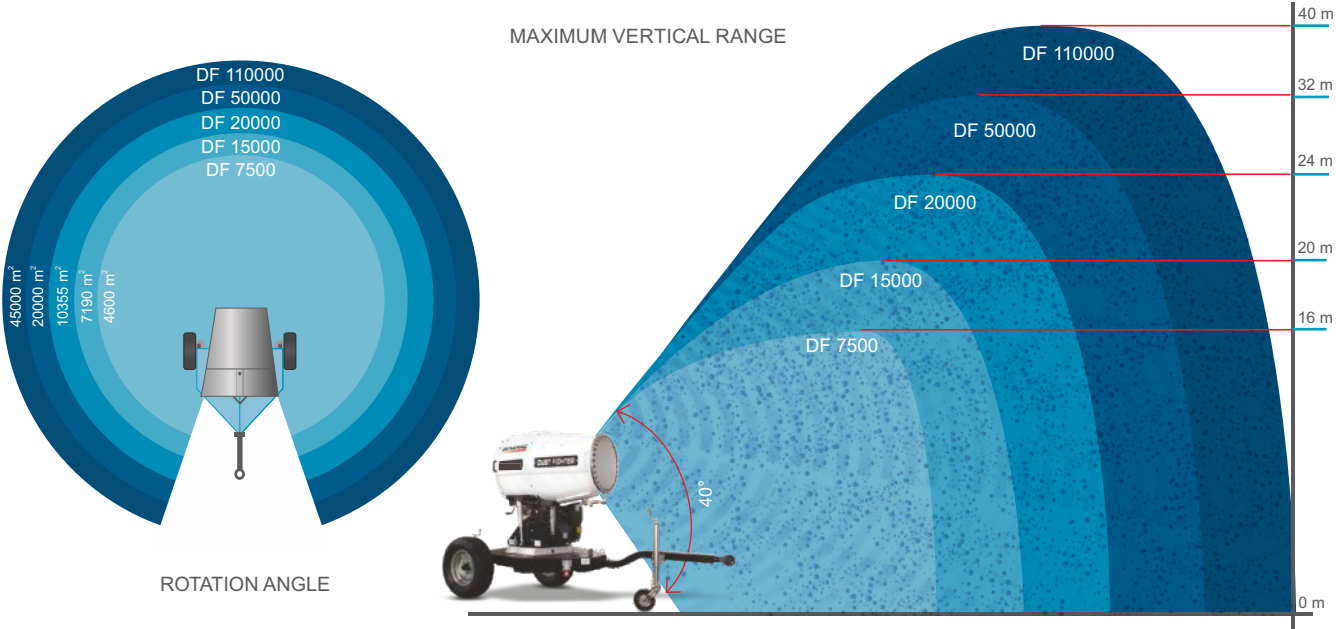

MAXIMUM HORIZONTAL RANGE

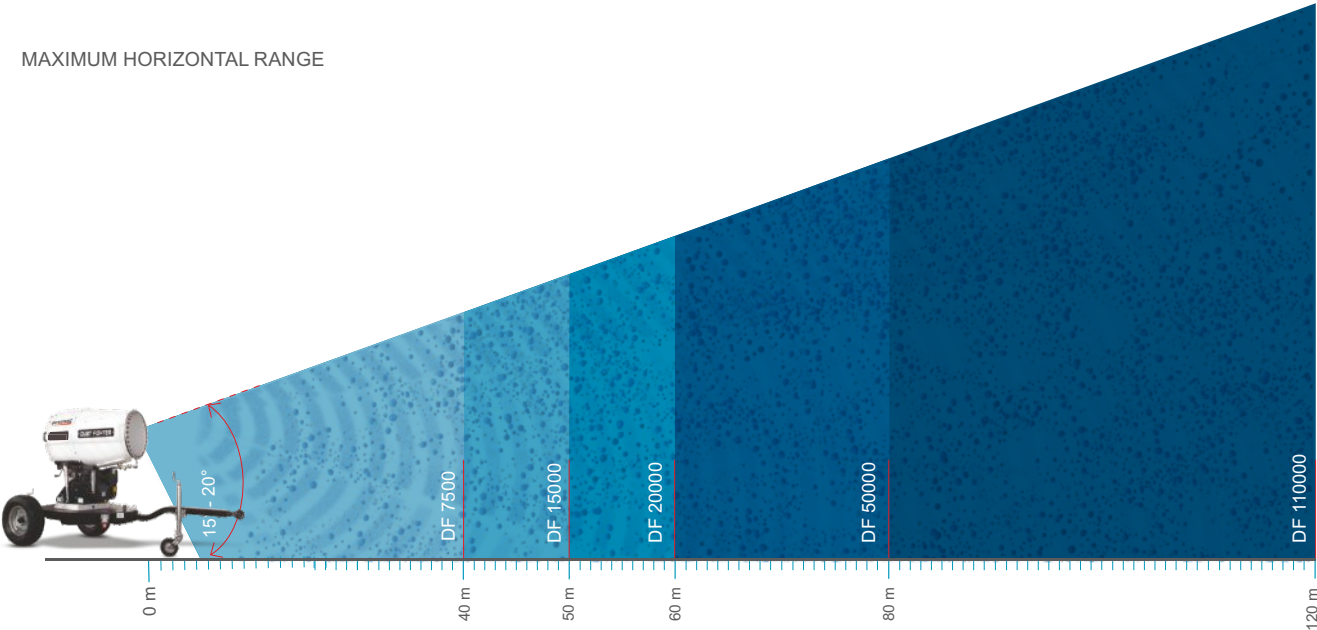

DF 7500 - DF 15000 - DF 20000



TECHNICAL SPECIFICATIONS	DF 7500	DF 15000	DF 20000
Electrical engine power (fan)	7,5 kW	15 kW	22 kW
Smallest generator required	20 kW - three-phase	35 kW - three-phase	50 kW - three-phase
Coverage (without wind)	30 - 40 m	40 - 50 m	50 - 60 m
Electrical connection	Inlet plug three-phase - 32 A	Inlet plug three-phase - 32 A	Inlet plug three-phase - 63 A
Water connection	UNI 45 / STORZ / CAMLOCK	UNI 45 / STORZ / CAMLOCK	UNI 45 / STORZ / CAMLOCK
Minimum inlet pressure	1,0 bar	1,0 bar	1,0 bar
Water consumption	52 L/min	60 L/min	70 L/min
Water inlet filter	180 µm	180 µm	180 µm
Working angle	335°	335°	335°
Tilting	0 - 40°	0 - 40°	0 - 40°
Dimensions with tow bar and wheels (L x W x H)	3300 x 1830 x 2180 mm	3300 x 1830 x 2180 mm	3300 x 1830 x 2180 mm
Weight	760 kg	810 kg	850 kg

STANDARD EQUIPMENT

- Integrated control panel
- Phase inverter
- Booster pump with peripheral impeller
- Flowmeter for pump protection
- Pressure gauge for outlet pressure reading
- Stainless steel crown with nozzles
- Water drain system
- Equipped with 2 wheels, tow bar and forklift pockets
- 2 height adjustable stabilizers

OPTIONAL

- Remote control
- Available on homologated road trailer type C (adjustable)
- Documents for road registration CE
- Automatic rotation system
- Electric tilting
- Dosing pump for chemical additives
- Water supply pump
- Arctic kit
- Side forklift pockets (for low speed trailer only)
- Dedicated colour (RAL) (for spray cannon only)
- Hitch: 50mm ball or 68mm eyelet

MAXIMUM HORIZONTAL RANGE

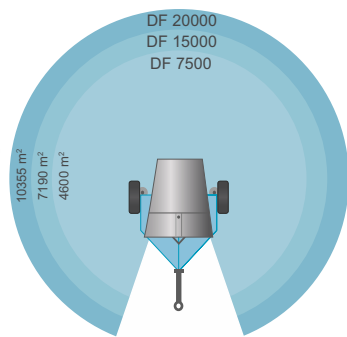
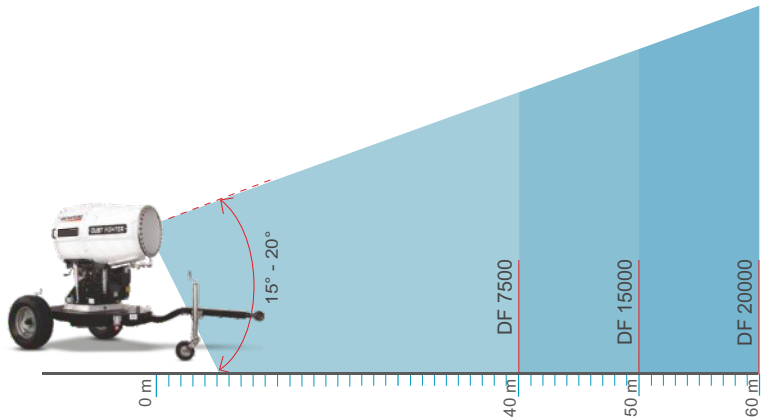

ROTATION ANGLE



DF 50000



TECHNICAL SPECIFICATIONS	DF 50000
Electrical engine power (fan)	45 kW
Smallest generator required	100 kW - three-phase
Coverage (without wind)	70 - 80 m
Electrical connection	Inlet plug three-phase - 125 A
Water connection	UNI 45 / STORZ / CAMLOCK
Minimum inlet pressure	1,0 bar
Water consumption	125 L/min
Water inlet filter	180 µm
Working angle	340°
Tilting	0 - 35°
Dimensions on base (L x W x H)	2270 x 1450 x 2320 mm
Weight	1410 kg

STANDARD EQUIPMENT

- Integrated control panel
- Phase inverter
- Booster pump with peripheral impeller
- Flowmeter for pump protection
- Pressure gauge for outlet pressure reading
- Stainless steel crown with nozzles
- Water drain system
- Mounted on base with forklift pockets
- Automatic rotation system
- Electric tilting
- Remote control to switch on/off the fan, the pump and the electrical rotation, complete with macro-sequential controls

OPTIONAL

- Low speed trailer (no brakes)
- Dosing pump for chemical additives
- Water supply pump
- Dedicated colour (RAL) (for spray cannon only)

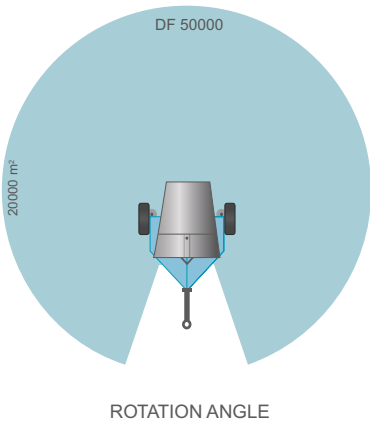
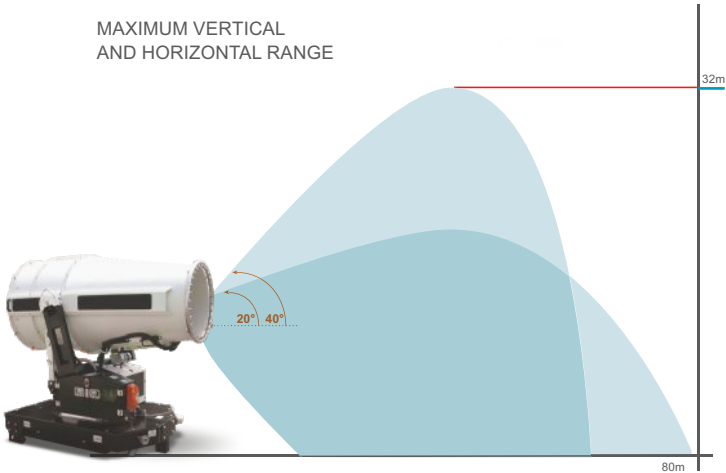

DF 110000



TECHNICAL SPECIFICATIONS	DF 110000
Electrical engine power (fan)	108 kW
Coverage (without wind)	110 - 120 m
Water connection	UNI 45 / STORZ / CAMLOCK
Minimum inlet pressure	1,0 bar
Water consumption	150 - 315 L/min
Water inlet filter	180 µm
Working angle	320°
Tilting	0 - 40°
Dimensions without electrical cabinet (L x W x H)	2500 x 2200 x 2470 mm
Dimensions of electrical cabinet (L x W x H)	1300 x 700 x 2150 mm
Weight (without electrical cabinet)	2900 kg
Weight of electrical cabinet	475 kg

Values may vary depending on requested tensions and frequencies.

STANDARD EQUIPMENT

- Control panel on separated electrical cabinet
- Integrated multistage water pump
- Flowmeter for pump protection
- Pressure gauge for outlet pressure reading
- Double stainless steel crown with nozzles
- Water drain system
- Mounted on base with forklift pockets
- Electric tilting
- Automatic rotation system
- Remote control to switch on/off the fan, the pump and the electrical rotation, complete with macro-sequential controls

OPTIONAL

- Dosing pump for chemical additives
- Water supply pump
- Dedicated colour (RAL) (for spray cannon only)

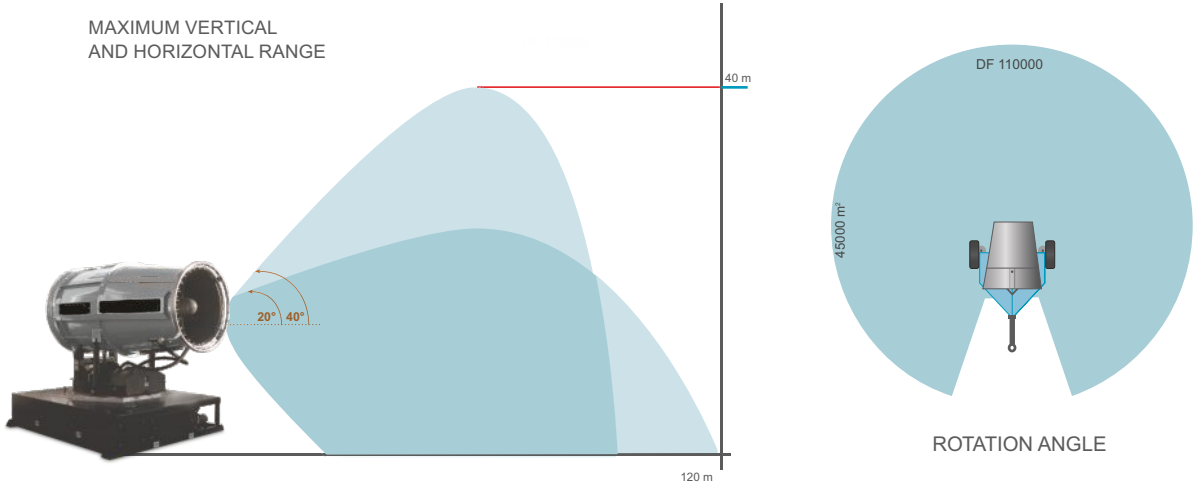

DF 3000 MPT



TECHNICAL SPECIFICATIONS	DF 3000 MPT
Electrical engine power (fan)	2,2 kW
Coverage (without wind)	20 m
Integrated generating set	3,7 kW - 230 V - Yanmar L70
Fuel tank capacity	18 L
Water tank capacity	1000 L
Water consumption	6,25 L/min
Running time	160 min
Water inlet filter	170 µm
Working angle	335°
Manual tilting system	-30° / +10°
Dimensions on base (L x W x H min/max)	2380 x 1210 x 2230/3920 mm
Dimensions on road trailer Type A* (L x W x H min/max)	3920 x 2015 x 2780/4470 mm
Dry weight on base / on road trailer*	490 / 800 kg

* option

STANDARD EQUIPMENT

- Telescopic vertical mast (max. height: 4m)
- 1000 litres plastic water tank
- 3,7 kW - 230 V integrated generating set
- Integrated control panel
- Stainless steel crown with nozzles
- Nebulizer cone foldable for shipment
- Telescopic mast with double crank winch
- Water Supply and Main Electricity network connections
- High pressure washer connection
- Water drain system
- Structure on base version with forklift pockets

OPTIONAL

- Low speed trailer (without brakes)
- Road trailer type A (straight) with 50mm ball hitch
- Road trailer type CM (adjustable) with 50mm ball hitch
- Documents for road registration CE

MAXIMUM HORIZONTAL RANGE

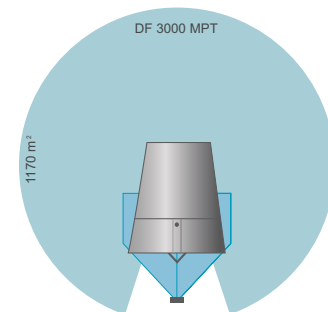
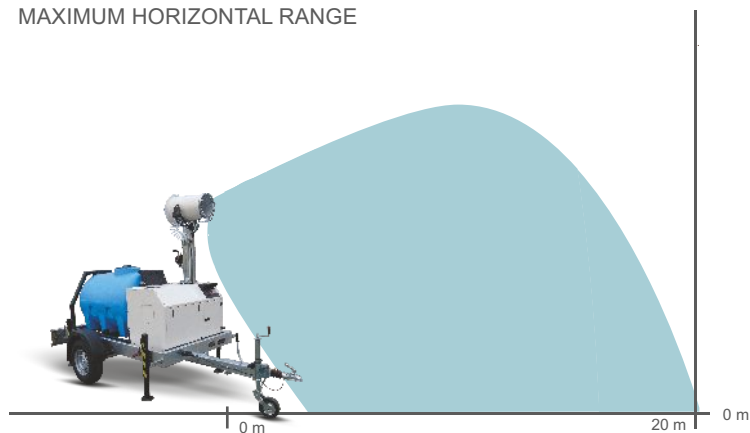

ROTATION ANGLE



DF 7500 MPT



TECHNICAL SPECIFICATIONS	DF 7500 MPT
Electrical engine power (fan)	7,5 kW
Coverage (without wind)	30 - 40 m
Integrated generating set	17 kW - diesel engine - 1500 rpm
Fuel tank capacity	68 L
Water tank capacity	2000 L
Working pressure	7 - 12 bar
Water consumption (1 pump / 2 pumps)	23 L/min (7 bar) / 35 L/min (12 bar)
Running time (1 pump / 2 pumps)	85 min (7 bar) / 60 min (12 bar)
Water inlet filter	180 µm
Working angle	335°
Tilting	0 - 40°
Dimensions with tow bar and wheels (L x W x H)	4450 x 2240 x 2640 mm
Dry weight with tow bar and wheels	2450 kg

STANDARD EQUIPMENT

- 2000 litres water tank, 100% stainless steel
- 17 kW integrated generating set
- Complete with 4 wheels, tow bar and forklift pockets
- Automatic rotation system
- Integrated control panel
- 2 booster pumps with peripheral impellers
- Flowmeter for pump protection
- Pressure gauge for outlet pressure reading
- Stainless steel crown with nozzles
- Water drain system
- 4 height adjustable stabilizers
- Electric tilting
- Remote control to switch on/off the fan, the pump and the electrical rotation

OPTIONAL

- Low speed trailer (without brakes)
- Dosing pump for chemical additives
- Arctic kit
- 110V kit for the generating set
- Remote control for the generating set
- Double nozzles holder crown
- Dedicated colour (RAL) (for spray cannon only)
- Rigid adjustable drawbar with 76mm eyelet hitch (for low speed trailer only)

MAXIMUM VERTICAL AND HORIZONTAL RANGE

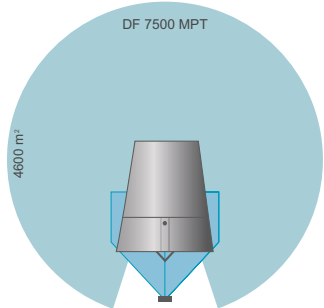
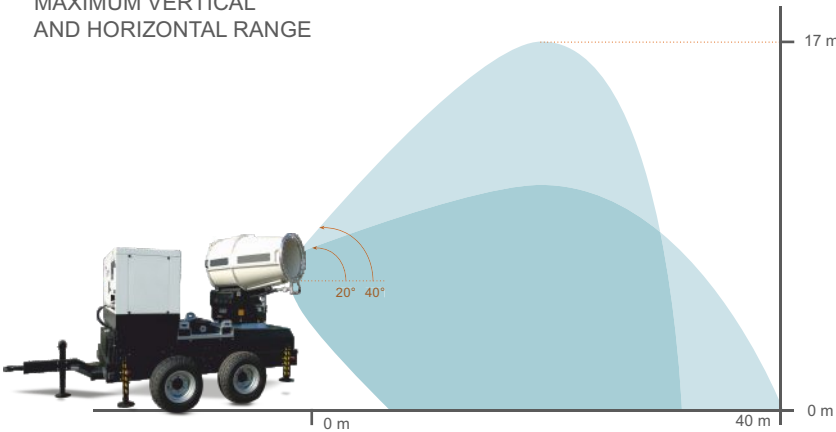

ROTATION ANGLE



DF MINI



STANDARD EQUIPMENT

- Stainless steel 70 L water tank
- 3 interchangeable type of nozzles for different coverages
- Wheels and handles for transport
- High pressure pump
- Signal for low water level
- Adjustable for an easy transport
- Manually adjustable nozzles spray angle

OPTIONAL

- Connection from the Water Supply network
- 110V Kit
- Dedicated colour (RAL)
- Plastic box for documents

TECHNICAL SPECIFICATIONS	DF MINI
Pump	230 V - 50 Hz - 2,6 A - 0,55 Kw - 100 bar
Nozzles spray angle	From 80° to 150°
Tilting head (high - low)	25° - 15°
3 different nozzles available	Type 1: Distance: 8 m - Running time 1 h 20 min - Coverage: 83 m ² Type 2 (std.): Distance: 7 m - Running time 2 h 25 min - Coverage: 64 m ² Type 3: Distance: 5 m - Running time 5 h 18 min - Coverage: 33 m ²
Water tank capacity	70 L
Dimensions (L x W x H min/max)	710 x 600 x 1300/2150 mm
Dry weight	70 kg

DF MINI DUO ASB

IDEAL FOR ASBESTOS REMOVAL



STANDARD EQUIPMENT

- Stainless steel 70 L water tank
- 3 interchangeable type of nozzles for different coverages
- Wheels and handles for transport
- High pressure pump
- Signal for low water level
- Adjustable satellites for an easy transport
- Manually adjustable nozzles spray angle

OPTIONAL

- Connection from the Water Supply network
- Dedicated colour (RAL)
- 110V Kit
- Plastic box for documents

TECHNICAL SPECIFICATIONS	DF MINI DUO ASB
Pump	230 V - 50 Hz - 2,6 A - 0,55 Kw - 100 bar
Nozzles spray angle	From 80° to 150°
Tilting head (high - low)	25° - 15°
3 different nozzles available	Type 1: Distance: 8+8 m - Running time 40 min - Coverage: 83+83 m ² Type 2 (std.): Distance: 7+7 m - Running time 1 h 12 min - Coverage: 64+64 m ² Type 3: Distance: 5+5 m - Running time 2 h 40 min - Coverage: 33+33 m ²
Water tank capacity	70 L
Main unit dimensions (L x W x H)	710 x 600 x 1030 mm
Satellite dimensions (L x W x H)	620 X 370 X 1800 mm
Main unit dry weight	61 kg
Satellite weight (each)	21,5 kg

DF SMART



STANDARD EQUIPMENT

- Wheels and handles for transport
- Stainless steel crown with nozzles
- Water inlet filter
- Emergency stop button
- Manual tilting system

OPTIONAL

- Forklift pockets
- Plastic box for documents
- Dedicated colour (RAL)
- 10m electrical cable with Schuko plug
- 110V Kit

TECHNICAL SPECIFICATIONS	DF SMART
Electrical engine	Single-phase 230 V - 50 Hz - 2,2 kW
Electrical connection	Single-phase socket - 16 A - IP 67
Water connection	Express type ½" quick connection
Fan	9 nylon blades, aluminium hub
Air flow	90 m³/min
Coverage (without wind)	13 m
Nominal pressure	From 1 up to 5 bar
Water inlet filter	300 µm
Tilting angle	From 10° up to 50°
Dimensions (L x W x H)	985 x 785 x 835 mm
Weight	79 kg
Water consumption	1.0 bar - 5.4 L/min 1.5 bar - 6.6 L/min 2.0 bar - 7.5 L/min 2.5 bar - 8.5 L/min

DF MINI MAXIMUM HORIZONTAL RANGE

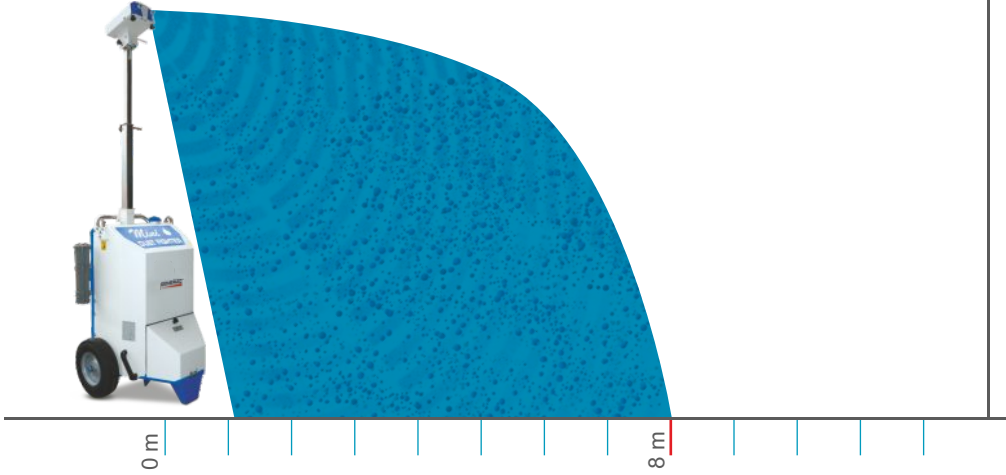

DF MINI DUO MAXIMUM HORIZONTAL RANGE

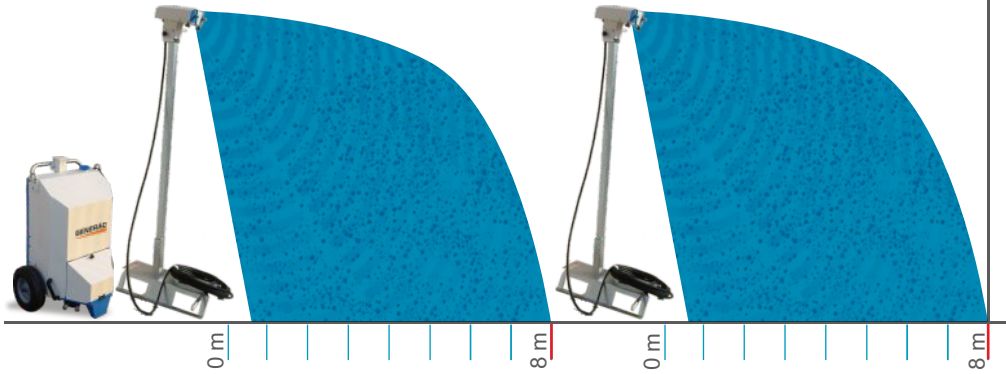

DF SMART MAXIMUM HORIZONTAL RANGE

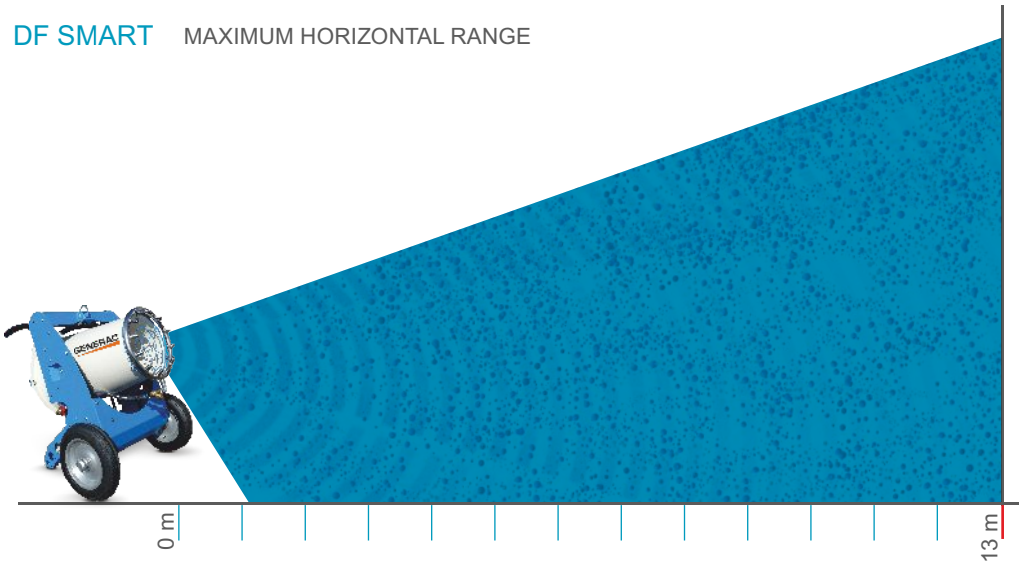

APPLICATION FIELDS

Ideals for: indoor demolitions with hammers and robots, recycling, aggregate production, renovations and repairs, concrete and pavement removal, wall cutting processes and waste treatment.



DISTRIBUTOR:

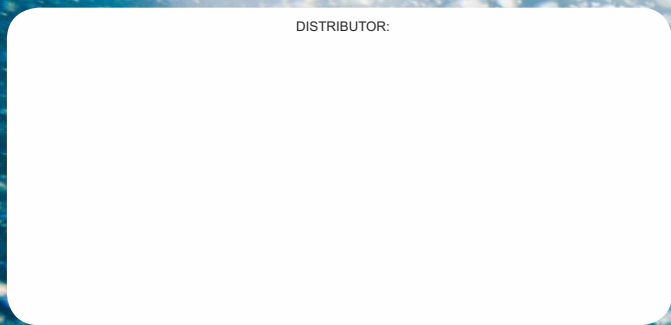

GENERAC[®] | **MOBILE**

Generac Mobile Products Srl
Part of Generac Power Systems, Inc.
Via Stazione, 3 bis - 27030 Villanova d'Ardenghi (PV) - Italy
Tel +39.0382.567011 - gmp.srl@generac.com
www.generacmobile.com